

HiMARK Technology, Inc. reserves the right to change the product described in this datasheet. All information contained in this datasheet is subject to change without prior notice. HiMARK Technology, Inc. assumes no responsibility for the use of any circuits shown in this datasheet.

Description

The TX4915 is a low power ASK transmitter IC intended for applications in the North American and European VHF/UHF bands. The integrated voltage-controlled oscillator (VCO), phase/frequency detector, prescaler, and reference oscillator require only the addition of an external crystal to provide a complete phase-locked loop (PLL). In addition to the standard power-down mode, the chip also includes an automatic lock-detect feature that disables the transmitter output when the PLL is out-of-lock.

Features

- ◆ Output frequency range: 100 – 960 MHz
- ◆ Supply voltage range: 2.2 – 3.6 V
- ◆ Low current consumption with power down capability
- ◆ On-chip VCO with integrated PLL ($\div 64/128$) dual modulus prescaler
- ◆ Out-of-lock inhibit circuit
- ◆ SSOP-16 package (0.64 mm pitch)

Applications

- ◆ Wireless mouse
- ◆ Car alarm and home security systems
- ◆ Remote control systems

Block Diagram

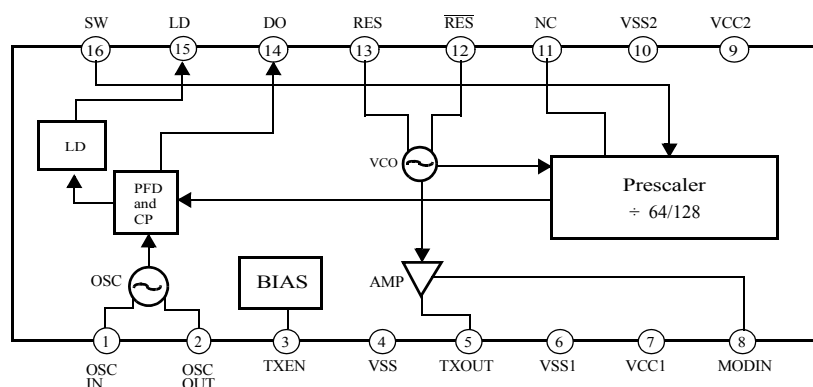

Package and Pin Assignment

SSOP-16 (0.64mm pitch)

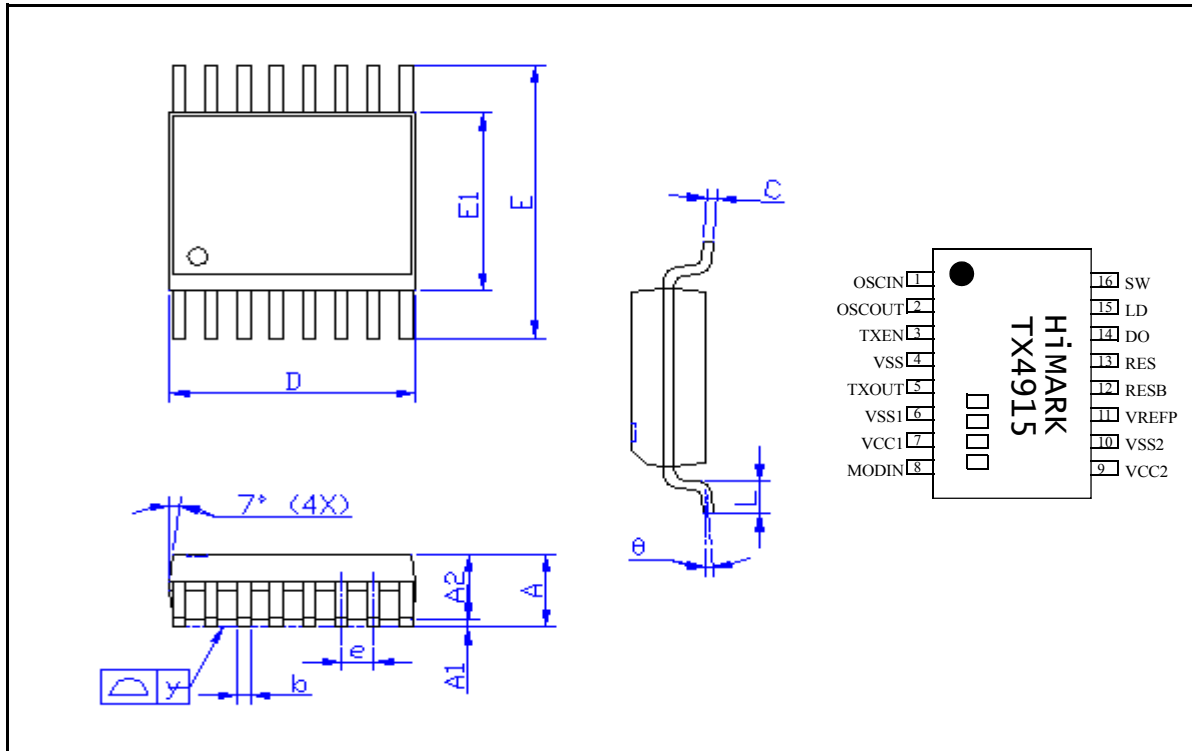

| Symbol | Dimensions in mm | | | Dimensions in inches | | |
|--------|------------------|------|------|----------------------|-------|-------|
| | min. | nom. | max. | min. | nom. | max. |
| A | 1.35 | 1.60 | 1.75 | 0.053 | 0.064 | 0.069 |
| A1 | 0.10 | — | 0.25 | 0.004 | — | 0.010 |
| A2 | — | 1.45 | — | — | 0.057 | — |
| b | 0.20 | 0.25 | 0.30 | 0.008 | 0.010 | 0.012 |
| C | 0.19 | — | 0.25 | 0.007 | — | 0.010 |
| D | 4.80 | — | 5.00 | 0.189 | — | 0.197 |
| E | 5.80 | — | 6.20 | 0.228 | — | 0.244 |
| E1 | 3.80 | — | 4.00 | 0.150 | — | 0.157 |
| e | — | 0.64 | — | — | 0.025 | — |
| L | 0.40 | — | 1.27 | 0.016 | — | 0.050 |
| y | — | — | 0.10 | — | — | 0.004 |
| θ | 0° | — | 8° | 0° | — | 8° |

Pin Descriptions

| Number | Name | Description |
|--------|------------------|--|
| 1 | OSCIN | This pin is connected directly to the base of the reference oscillator transistor. The reference oscillator uses a modified Colpitts configuration. |
| 2 | OSCOU | This pin is connected directly to the emitter of the reference oscillator transistor. |
| 3 | TXEN | Transmitter enable control (TXEN = low = power down mode; TXEN = high = normal operation mode). |
| 4 | VSS | Ground connection for the transmit output amplifier. |
| 5 | TXOUT | Transmitter output. This pin is an open collector output and requires a pull-up inductor for bias/matching and a tapped capacitor network for matching. |
| 6 | VSS1 | Ground connection for the transmit driver amplifier. |
| 7 | VCC1 | Nominal supply voltage for the transmit driver amplifier. |
| 8 | MODIN | ASK modulation input. An external resistor, R_{MODIN} , connected from the MODIN pin to supply voltage is used to bias the transmit amplifier chain. |
| 9 | VCC2 | Nominal supply voltage for the VCO and PLL circuitry. |
| 10 | VSS2 | Ground connection for the PLL circuitry. |
| 11 | NC | No connection. |
| 12 | \overline{RES} | Differential open collector VCO outputs. |
| 13 | RES | |
| 14 | DO | Output of the charge pump. An R-C network from this pin to ground is used to establish the PLL bandwidth. |
| 15 | LD | Lock detector output. This pin is used to set the threshold of the lock detect circuitry which enables or disables the transmit amplifier. A shunt capacitor should be used to set an R-C time constant with the on-chip series 1 K Ω resistor. The time constant should be set to approximately 15 times the reference period. |
| 16 | SW | Prescaler modulus control input (SW = high = $\div 64$; SW = low = $\div 128$). |

Absolute Maximum Ratings

 $V_{SS}, V_{SS1}, V_{SS2} = 0V$

| Parameter | Rating | Unit |
|-------------------------------|------------------|------|
| Supply voltage range | -0.3 to +3.6 | V |
| Power-down voltage | -0.3 to V_{CC} | V |
| MODIN voltage | -0.3 to +1.1 | V |
| Operating ambient temperature | -40 to +85 | °C |
| Storage temperature | -40 to +150 | °C |

Recommended Operating Conditions

 $V_{SS}, V_{SS1}, V_{SS2} = 0V$

| Parameter | Symbol | Value | | | Unit |
|-----------------------|----------|-------|------|------|------|
| | | min. | typ. | max. | |
| Supply voltage range | V_{CC} | 2.2 | 3.0 | 3.6 | V |
| Operating temperature | T_A | -10 | +25 | +60 | °C |

Electrical Characteristics

($V_{CC} = 3\text{ V}$, V_{SS} , V_{SS1} , $V_{SS2} = 0\text{ V}$, TXEN = high, $T_A = 25\text{ }^\circ\text{C}$, and $f_{RF} = 433.92\text{ MHz}$ unless otherwise noted)

| Parameter | Symbol | Condition | Value | | | Unit |
|-------------------------------------|---------------|--|-------------------------|------|------|---------------|
| | | | min. | typ. | max. | |
| Power supply | | | | | | |
| Supply voltage | V_{CC} | | 2.2 | 3.0 | 3.6 | V |
| Total dc current (normal operation) | I_{CC} | 50% duty cycle, 10 KHz data applied to the MODIN pin ($R_{MODIN} = 10\text{ K}\Omega$) | | 10.5 | | mA |
| Total dc current (power-down mode) | $I_{standby}$ | TXEN = low | | | 1 | μA |
| Overall | | | | | | |
| RF input frequency range | f_{RF} | | 100 | | 960 | MHz |
| Modulation | | | | ASK | | |
| Modulation frequency | f_{MOD} | | | | 100 | KHz |
| Output power | P_{OUT} | 50 Ω load | 1 | 8 | | dBm |
| ON/OFF ratio | | | | 70 | | dB |
| PLL | | | | | | |
| Prescaler divide ratio | | SW = high = $\div 64$ SW = low = $\div 128$ | 64 | | 128 | |
| VCO gain | K_{VCO} | Frequency and board layout dependent | | 20 | | MHz/V |
| Phase noise | | 10 KHz offset, 50 KHz loop BW | | -80 | | dBc/Hz |
| | | 100 KHz offset, 50 KHz loop BW | | -89 | | dBc/Hz |
| 2nd harmonic | | | | -30 | | dBc |
| 3rd harmonic | | | | -40 | | dBc |
| Reference frequency | | | | 7 | | MHz |
| Crystal frequency spurs | | 50 KHz PLL loop BW | | -50 | | dBc |
| Charge pump current | I_{CP} | | -100 | | 100 | μA |
| Stand-by mode control | | | | | | |
| Transmitter enable/disable voltage | | TXEN = high = normal operation | $V_{CC} - 0.3\text{ V}$ | | | V |
| | | TXEN = low = power-down mode | | | 0.3 | V |
| Turn-on time | | | | 1 | 2 | ms |
| Turn-off time | | | | 1 | 2 | ms |

Functional Description

The TX4915 is a low-power ASK transmitter IC designed for applications operating within the frequency range of 100 to 960 MHz. In particular, it is intended for transmitter applications in 315/433 MHz band remote keyless entry and 868/915 MHz ISM-band systems. In addition, the TX4915 possesses a PLL-only mode which allows it to be simply used as a local oscillator source. The integrated voltage-controlled oscillator (VCO), phase/frequency detector, prescaler, and reference oscillator require only the addition of an external crystal to provide a complete phase-locked loop. In addition to the normal operation mode, the chip also includes an automatic lock-detect feature that disables the transmitter output when the PLL is out-of-lock.

Reference crystal oscillator

The OSCIN and OSCOUT inputs (pins 1 and 2) provide connections to an on-chip transistor which may be used to implement a Colpitts crystal oscillator. The Colpitts oscillator configuration is a low parts count topology which achieves reasonable phase noise performance. Optionally, an external signal may be ac-coupled into the OSCIN pin to provide a reference source. The OSCIN input drive level should be near 500 mV_{pk-pk} to prevent overdriving the on-chip transistor in order to keep the phase noise and reference spurs to a minimum.

Voltage controlled oscillator

The VCO uses a tuned differential amplifier topology with the bases and collectors cross-coupled to provide positive feedback and the necessary 360° phase shift. A tuned circuit is connected to the open collector outputs and is comprised of both on-chip varactors and user-selectable off-chip inductors. The choice of inductor values determines the frequency band of operation.

Dual-modulus prescaler

A series of flip-flops divides the VCO frequency by either 64 or 128, depending upon the logic level of the SW input (pin 16). SW = high will select the ÷ 64 mode and SW = low will select the ÷ 128 mode. The divided-down signal is then applied to the phase/frequency detector where its phase/frequency is compared with the phase/frequency of the crystal reference.

Phase/frequency detector and charge pump

The phase/frequency detector (PFD) is implemented using the “tri-state comparator” topology while the charge pump (CP) consists of a current source and sink for charging and discharging the off-chip loop filter. When the VCO and reference inputs to the PFD are both phase- and frequency-locked, the CP output enters a high impedance state. Otherwise, the CP will either charge or discharge the loop filter.

Out-of-lock inhibit circuitry

The out-of-lock inhibit circuitry is used to disable the transmitter output when the VCO is not locked to the reference oscillator and comply with regulatory limits during the unlocked condition. An off-chip shunt capacitor connected to the LD output (pin 15) is used to set an R-C time constant (together with an on-chip series 1 KΩ resistor.) This time constant should be set to be approximately 15 times the reference period.

Transmit amplifier chain

A transmit amplifier chain consists of a driver amplifier followed by an open collector output stage. The open collector TXOUT output (pin 5) requires an external pull-up inductor for bias. This inductor may be used as part of an L-C matching circuit for transforming the amplifier output impedance to that of an external loop antenna. To achieve optimum power-added efficiency, the peak-to-peak RF voltage swing at the TXOUT pin should be twice the supply voltage. Also, the output amplifier has its own ground pin (VSS) in order to improve isolation.

The transmitter chain is designed for amplitude-shift-keying/on-off keying (ASK/OOK), with the modulation data provided at the MODIN input (pin 8). When $V_{\text{MODIN}} > 0.7 \text{ V}$, an output signal is transmitted, and when $V_{\text{MODIN}} \leq 0.7 \text{ V}$, no output signal is transmitted.

Operation modes

The table below summarizes the TX4915's three operating modes — power-down, PLL-only and transmit, which are controlled by the TXEN and MODIN inputs.

| TXEN | MODIN | Operation Mode |
|------|---------|----------------|
| L | L | Power-down |
| H | L | PLL-only |
| H | > 0.7 V | Transmit |

Application Circuits

$f_{RF} = 315 \text{ MHz}$

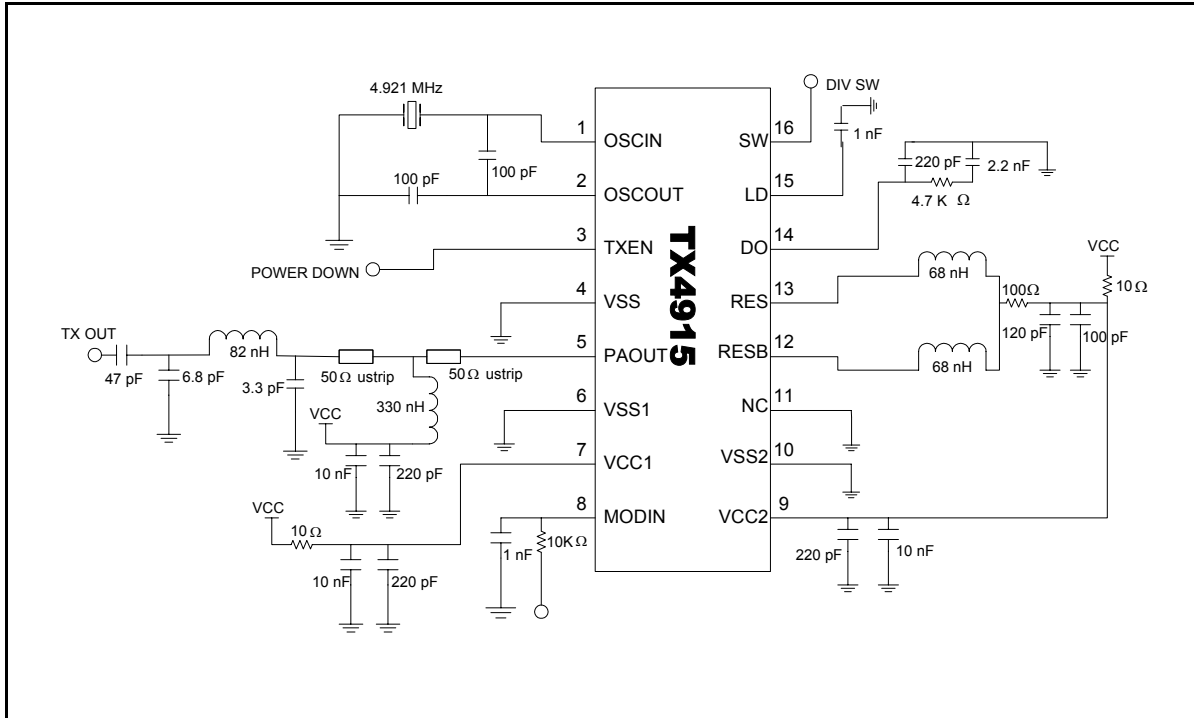

$f_{RF} = 434 \text{ MHz}$

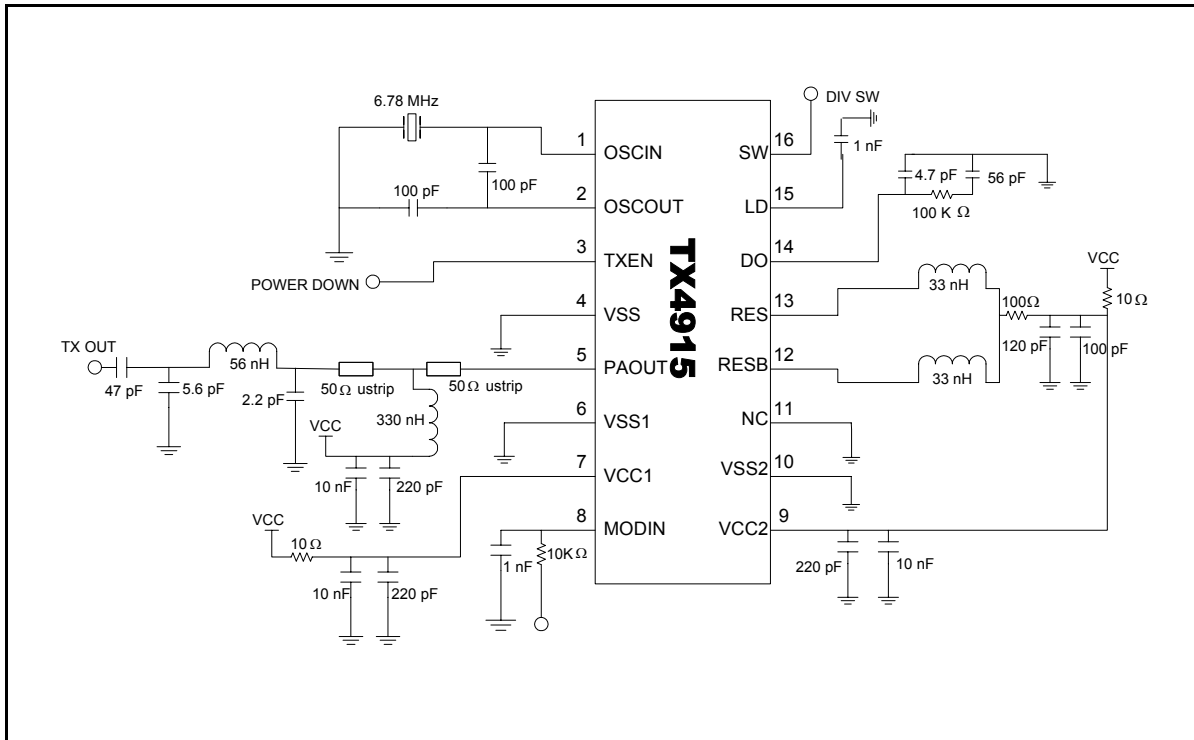

$f_{RF} = 868 \text{ MHz}$

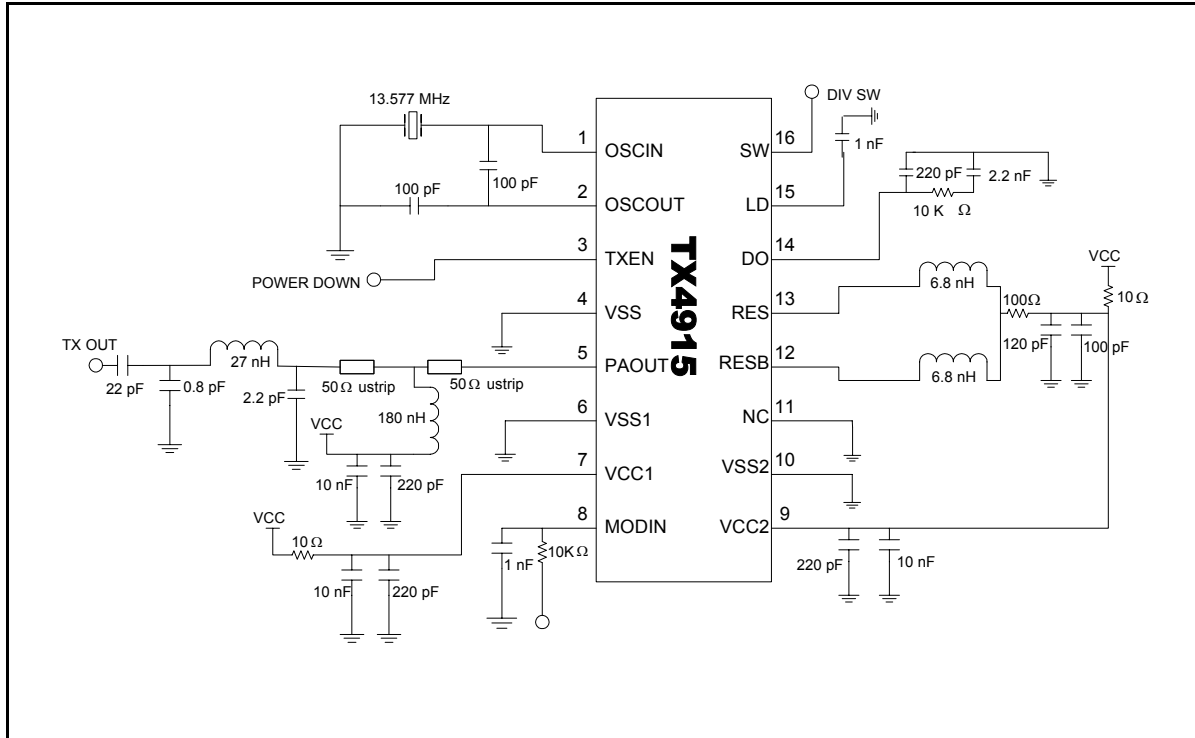

Typical Performance Characteristics

Output Power vs. R_{MODIN} ($f_{RF} = 433 \text{ MHz}$)

| R_{MODIN} (Ω) | $V_{CC} = 2.0 \text{ V}$ | | $V_{CC} = 2.4 \text{ V}$ | | $V_{CC} = 2.8 \text{ V}$ | | $V_{CC} = 3.2 \text{ V}$ | | $V_{CC} = 3.6 \text{ V}$ | |
|-----------------------------|--------------------------|--------------------|--------------------------|--------------------|--------------------------|--------------------|--------------------------|--------------------|--------------------------|--------------------|
| | I_{CC} (mA) | P_{OUT} (dBm) | I_{CC} (mA) | P_{OUT} (dBm) | I_{CC} (mA) | P_{OUT} (dBm) | I_{CC} (mA) | P_{OUT} (dBm) | I_{CC} (mA) | P_{OUT} (dBm) |
| 1 K | 18.4 | 4.4 | 22.2 | 6.1 | 25.8 | 7.2 | 30.0 | 8.1 | 36.5 | 8.6 |
| 3 K | 16.7 | 4.6 | 19.6 | 6.0 | 21.3 | 7.1 | 24.0 | 8.1 | 26.7 | 9.0 |
| 5 K | 15.8 | 4.2 | 18.5 | 5.5 | 20.4 | 6.4 | 22.1 | 7.1 | 24.3 | 7.8 |
| 7 K | 15.1 | 3.6 | 17.7 | 4.9 | 19.6 | 5.7 | 20.7 | 6.4 | 22.3 | 7.1 |
| 9 K | 14.4 | 2.8 | 16.8 | 4.0 | 18.3 | 4.8 | 19.2 | 5.4 | 20.6 | 6.1 |
| 11 K | 13.5 | 1.7 | 15.7 | 3.0 | 17.2 | 3.9 | 18.5 | 4.6 | 19.9 | 5.3 |
| 13 K | 13.1 | 1.2 | 15.1 | 2.4 | 16.3 | 3.1 | 17.5 | 3.7 | 18.5 | 4.2 |
| 15 K | 12.6 | 0.4 | 14.4 | 1.8 | 15.7 | 2.7 | 16.9 | 3.4 | 18.1 | 4.1 |
| 17 K | 12.3 | 0.1 | 14.1 | 1.4 | 15.1 | 2.2 | 16.2 | 2.8 | 17.3 | 3.3 |
| 19 K | 11.9 | -0.6 | 13.5 | 0.9 | 14.7 | 1.8 | 15.8 | 2.5 | 16.9 | 3.1 |
| 21 K | 11.5 | -1.1 | 11.5 | 0.4 | 14.2 | 1.2 | 15.1 | 1.8 | 16.2 | 2.4 |

Phase Noise

$f_{RF} = 433 \text{ MHz}$, $V_{CC} = 3.0 \text{ V}$, $R_{MODIN} = 3 \text{ K}\Omega$, 10 KHz offset

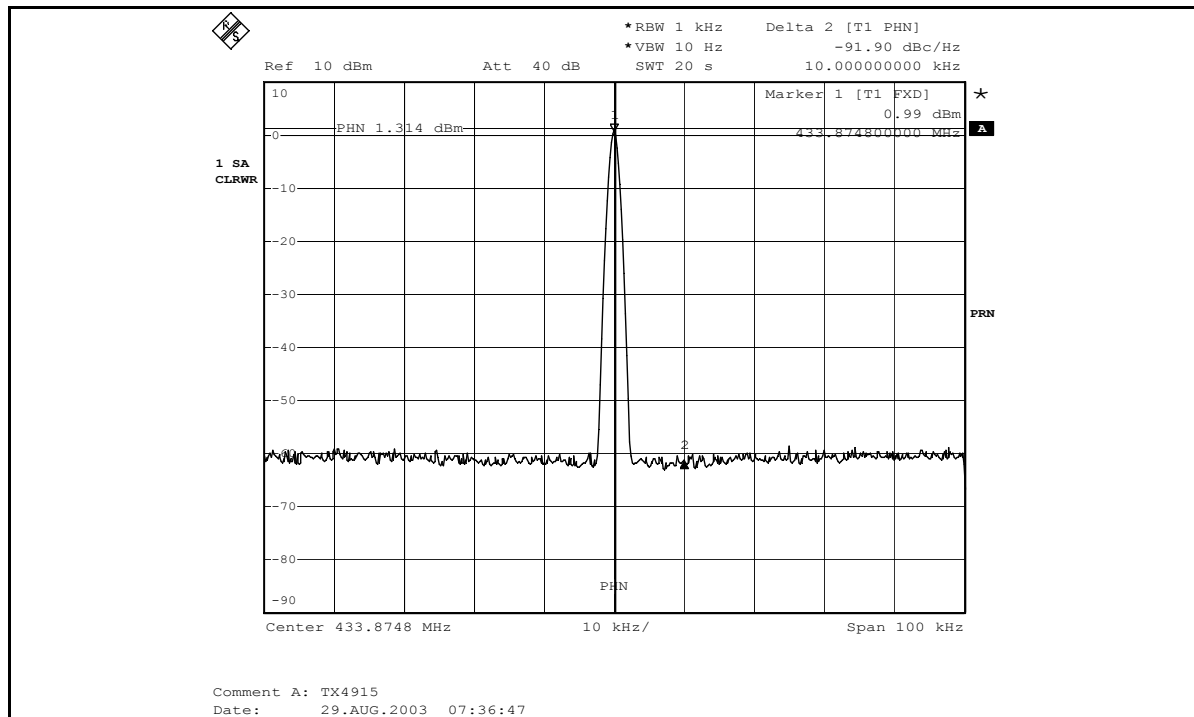

$f_{RF} = 433 \text{ MHz}$, $V_{CC} = 3.0 \text{ V}$, $R_{MODIN} = 3 \text{ K}\Omega$, 100 KHz offset

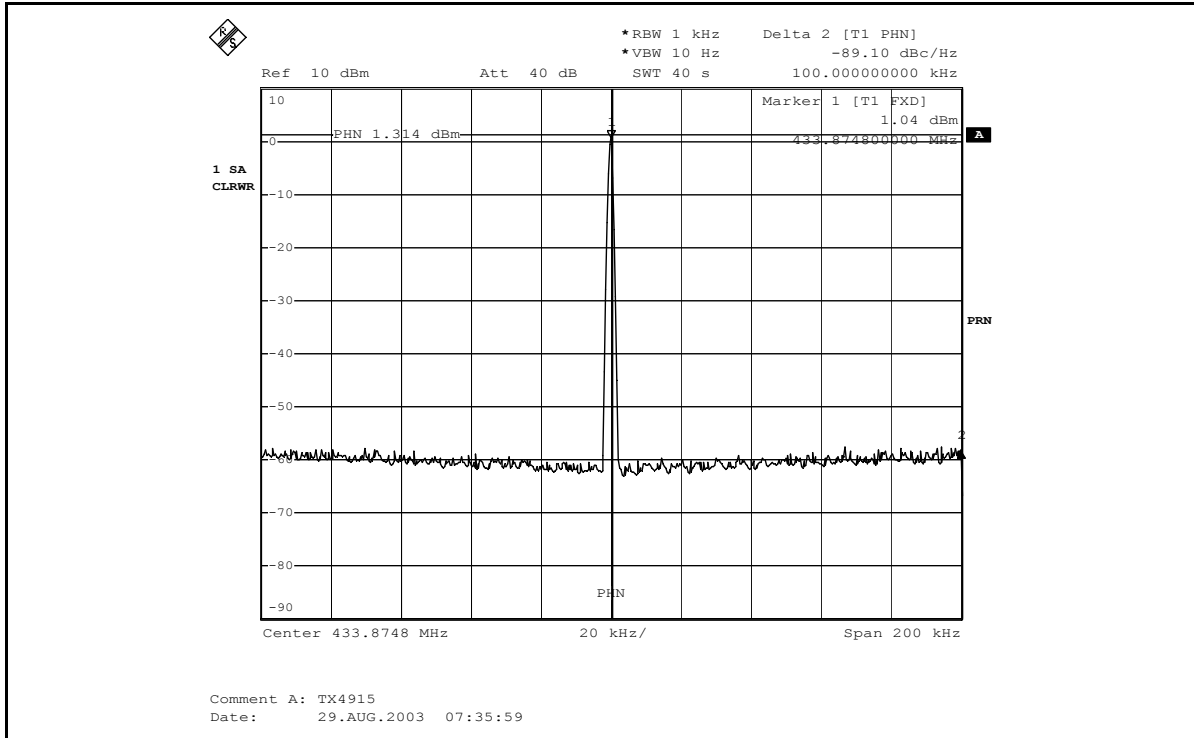

Output Impedance

